

# The Geometry of Polygon Spaces

Victor I. Piercey and Matthew Thomas

Advisor: Dr. Philip Foth

University of Arizona

December 6, 2007

## 1 Introduction

### 1.1 Moduli Spaces

*Moduli spaces* are parameter spaces of algebraic varieties. Moduli spaces of polygons are examples with a clear geometric meaning. The moduli space of a given polygon with fixed side lengths is defined as the space of deformations in 3-dimensional Euclidean space. The trivial case is the moduli space of a triangle. Since a triangle cannot be deformed while keeping side lengths fixed, the moduli space of a triangle is a point.

### 1.2 The Generic Quadrilateral

A simple example to keep in mind is a generic quadrilateral, shown below. The dotted line represents a diagonal. We refer to the length of this diagonal as the diameter and use the diameter as a parameter for the moduli space.

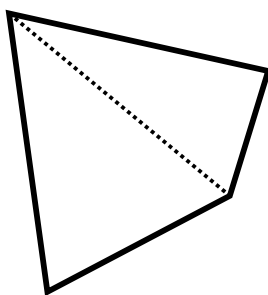

Given a specific diameter strictly between its minimum and maximum, we may rotate the upper right point around the diagonal. This gives us one degree of freedom and the moduli space with the fixed diameter is a circle.<sup>1</sup> When the diameter is a maximum or a minimum, the moduli space is a single point. Letting the diameter vary between its maximum and minimum, the moduli space of the generic quadrilateral is  $\mathbb{S}^2$ .

---

<sup>1</sup>If we rotated the lower right point, we would obtain equivalent quadrilaterals under identifications to be made below.

In general, a polygon which has one side significantly longer than the others will have moduli space  $\mathbb{C}\mathbb{P}^{n-3}$ . To make this precise would require a bit of work, so for now we will specify this to mean that one side length is equal to the sum of the other side lengths minus a small number  $\epsilon$ . Each side is a vector in  $\mathbb{R}^3$  that can be translated to the origin and normalized. Accordingly, each side corresponds to a point on the Riemann sphere. We specify without loss of generality that our first such point is located at  $\infty$  (the North pole) and the second at the origin (the South pole). We further require that our first side length is the longest side. As a consequence, in order for our polygon to be closed, no other side can be parallel to the first side.<sup>2</sup> Hence, no other points may be placed at  $\infty$  on the Riemann sphere. We are free to place each of our remaining  $n - 2$  points anywhere in the complex plane provided they are not all simultaneously placed at the origin. Finally, we form the quotient by the action of  $\mathbb{C}^*$ . This will identify polygons which are obtained by rotating about the  $z$ -axis in  $\mathbb{R}^3$ . It follows that the moduli space of an  $n$ -gon with one side significantly longer than the others is  $\mathbb{C}^{n-2} \setminus \{0\}$  modulo the action of  $\mathbb{C}^*$ . This is  $\mathbb{C}\mathbb{P}^{n-3}$  by definition.

## 2 Symplectic Geometry

### 2.1 Symplectic Forms

One of the primary tools we use to study moduli spaces of polygons is symplectic geometry. A *symplectic form* is a non-degenerate closed 2-form. A symplectic manifold is a manifold  $M$  with a symplectic form  $\omega$ . An example is  $\mathbb{S}^2$  in  $\mathbb{R}^3$ . One symplectic form on  $\mathbb{S}^2$  is defined by the map

$$\omega_p(u, v) := \langle p, u \times v \rangle$$

where  $u, v \in T_p(\mathbb{S}^2)$ . This defines a skew-symmetric bilinear form. Since it is a top degree form, it is closed. It is non-degenerate because if  $u \neq 0$ , then for  $v = u \times p$ ,  $\langle p, u \times v \rangle \neq 0$ .

### 2.2 The Moment Map

A specific type of map is essential for the results later in this paper. The moment map, or momentum map, expresses the fact that every symmetry in a mechanical system will force the existence of a conserved quantity. This map will be intimately tied to the GIT quotient, described below.

Let  $(M, \omega)$  be a symplectic manifold,  $G$  be a Lie group acting symplectically on  $(M, \omega)$ ,<sup>3</sup>  $\mathfrak{g}$  be its Lie algebra, and  $\mathfrak{g}^*$  be the dual vector space of  $\mathfrak{g}$ . In our case, it will suffice to think of the Lie group and its Lie algebra as matrix spaces. For each  $a \in \mathfrak{g}$ , there is an associated vector field on  $(M, \omega)$  which we will denote by  $x \mapsto a_x$ . The moment map for the action of  $G$  on  $(M, \omega)$  is a map  $\mu : (M, \omega) \rightarrow \mathfrak{g}^*$  which is  $G$  equivariant with respect to the action of  $G$  on  $M$  and the coadjoint action of  $G$  on  $\mathfrak{g}^*$  and satisfies:

$$\langle d\mu(x)(\xi), a \rangle = \omega_x(\xi, a_x) \quad \forall x \in M, \xi \in T_x M.$$

As an example, consider the action of  $\text{SO}(3)$  on  $\mathbb{S}^2$ . The moment map is the inclusion of  $\mathbb{S}^2$  into  $\mathbb{R}^3$ .

Note that not all actions admit moment maps. A symplectic action that admits a moment map is called a Hamiltonian action.

<sup>2</sup>Note that we will consider sides to be *parallel* if they point in exactly the same direction, and *anti-parallel* if they point in opposite directions.

<sup>3</sup>This means that the group action preserves the symplectic form  $\omega$ .

## 2.3 Symplectic Reduction

Consider a moment map:

$$\Phi_\omega : X \rightarrow \mathfrak{k}^*$$

where  $\mathfrak{k}$  is the Lie algebra of  $K$ , a compact Lie group which acts symplectically on  $X$ . Suppose  $K$  acts freely on  $\Phi_\omega^{-1}(0)$ . Then, by the Marsden-Weinstein-Meyer theorem, the orbit space  $\Phi_\omega^{-1}(0)/K$  is naturally a symplectic manifold. See Chapter 23 of [dS01] for the complete statement and proof. The connection between this symplectic quotient and the GIT quotient is discussed below.

## 3 Symplectic Geometry on the Moduli Space of Polygons

### 3.1 Basic Definitions

An  $n$ -gon is determined by a set of  $n$  points  $v_1, v_2, \dots, v_n$  in 3-dimensional Euclidean space. These points form the vertices of the polygon. The edges  $e_1, e_2, \dots, e_n$  will be formed by cyclically connecting the vertices. For  $1 \leq i \leq n-1$ ,  $e_i$  connects  $v_i$  and  $v_{i+1}$  and  $e_n$  connects  $v_n$  and  $v_1$ . If we consider the edges to be vectors in  $\mathbb{R}^3$ , we require

$$\sum_{i=1}^n e_i = 0$$

so that the polygon is closed. We identify polygons which can be obtained from each other by orientation-preserving isometries of  $\mathbb{E}^3$ . To do so, we first translate so that  $v_1$  lies at the origin. The remaining identifications come from the natural action of  $SO(3)$  on  $\mathbb{R}^3$ . The following diagrams illustrate possible 12-gons:

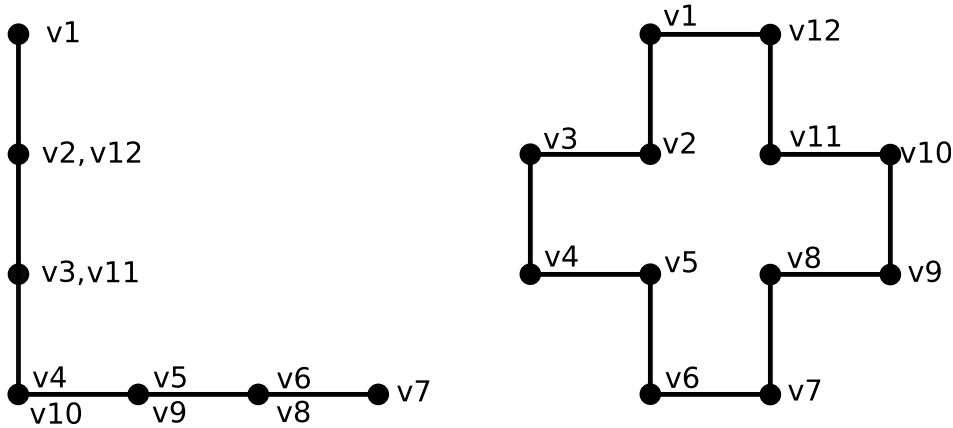

In operations, we can assume that parallel edges are adjacent, since we can always permute the edges and use the inverse of the permutation to return to the original polygon. We say that a set of edges is *degenerate* if that set of edges is a maximal set which is parallel in the polygon.

### 3.2 The Moduli Space $M_r$

If  $r = (r_1, \dots, r_n) \in \mathbb{R}_+^n$  is an  $n$ -tuple of positive real numbers, define  $M_r$  to be the space of  $n$ -gons with side lengths  $r_1, \dots, r_n$  modulo  $SO(3)$ . We can always rescale  $r$  since  $\forall \lambda \in \mathbb{R}_+$ , there is an isomorphism

$M_r \cong M_{\lambda_r}$ . We make the choice to normalize  $r$  so that

$$\sum_{i=1}^n r_i = 2.$$

If we set  $\mathcal{P}_n$  to be the space of all  $n$ -gons, we can define  $\pi : \mathcal{P} \rightarrow \mathbb{R}_+^n$  by assigning an  $n$ -gon  $P$  the vector whose components correspond to the lengths of the edges of  $P$ . The image of  $\pi$  lies in the hypersimplex

$$\mathbb{D}_2^n = \left\{ (x_1, \dots, x_n) \in \mathbb{R}^n : 0 \leq x_i \leq 1, \sum_i x_i = 2 \right\}.$$

It follows that  $M_r$  is the fiber  $\pi^{-1}(r)$  for  $r \in \mathbb{D}_2^n$ . We will assume for the rest of the paper that the side-length vector  $r$  is in the interior of the hypersimplex  $\mathbb{D}_2^n$ .

### 3.3 A Complex Analytic Structure on $M_r$

We now have the tools to define a complex analytic structure on  $M_r$ . Define the following subspace of  $(\mathbb{S}^2)^n$ :

$$\tilde{\mathcal{M}}_r = \left\{ \vec{u} \in (\mathbb{S}^2)^n : \sum_{i=1}^n r_i u_i = 0 \right\}.$$

Define  $\mathcal{M}_r = \tilde{\mathcal{M}}_r / \text{SO}(3)$ . If  $P \in M_r$ , normalizing the edges gives a collection  $u_i = e_i / r_i \in \mathbb{S}^2$ . The closing condition for  $P$  to be a polygon requires

$$\sum_{i=1}^n r_i u_i = 0.$$

This gives a homeomorphism

$$\epsilon : M_r \rightarrow \mathcal{M}_r$$

called the Gauss map.

We will define a complex analytic structure on  $M_r$  by recognizing  $\mathcal{M}_r$  as a symplectic quotient. Let  $\omega$  be the standard volume form on  $\mathbb{S}^2$  normalized so that

$$\int_{\mathbb{S}^2} \omega = 4\pi.$$

This is a Kähler form with respect to the standard complex analytic structure and Riemannian metric. For each  $i = 1, \dots, n$  let  $p_i : (\mathbb{S}^2)^n \rightarrow \mathbb{S}^2$  be the projection onto the  $i^{\text{th}}$  component. We then obtain a symplectic form (that is a Kähler form)  $\Omega$  on  $(\mathbb{S}^2)^n$  by

$$\Omega = \sum_{i=1}^n r_i p_i^*(\omega_i).$$

The space  $(\mathbb{S}^2)^n$  with the symplectic form  $\Omega$  is sometimes called the weighted configuration space. The diagonal action of the group  $\text{SO}(3)$  on  $((\mathbb{S}^2)^n, \Omega)$  is symplectic and Hamiltonian, giving rise to a moment map

$$\mu : (\mathbb{S}^2)^n \rightarrow \mathfrak{so}(3)^*.$$

Since we have a Lie algebra isomorphism  $\mathfrak{so}(3) \cong \mathbb{R}^3$ , where the Lie bracket on  $\mathbb{R}^3$  is the cross product, we can identify  $\mathfrak{so}(3)^*$  with  $(\mathbb{R}^3)^* \cong \mathbb{R}^3$ . With this identification, the moment map is given by

$$\mu(\vec{u}) = r_1 u_1 + \cdots + r_n u_n,$$

thus  $\tilde{M}_r = \mu^{-1}(0)$ . The condition  $\mu(r) = 0$  is precisely what is required for the polygon to be closed. Since  $\mathrm{SO}(3)$  is a compact group, it follows that  $\mathcal{M}_r = \mu^{-1}(0)/\mathrm{SO}(3)$  is the symplectic reduction of  $(\mathbb{S}^2)^n$  via the action of  $\mathrm{SO}(3)$ .

Now let  $\Sigma$  be the singularities of  $\mathcal{M}_r$ . It follows that  $\mathcal{M}_r \setminus \Sigma$  is a smooth symplectic reduction of a complex analytic manifold. The complex structure on  $(\mathbb{S}^2)^n$  is compatible with the symplectic form  $\Omega$ .<sup>4</sup> As a consequence, the symplectic reduction  $\mathcal{M}_r \setminus \Sigma$  is complex analytic. Under  $\epsilon^{-1}$ , the singularities of  $\mathcal{M}_r$  correspond to degenerate polygons in  $M_r$ , where a polygon is degenerate if it is a line-gon, that is there is a partition  $1, \dots, n = S_1 \cup S_2$  where  $e_i, i \in S_1$  are all parallel and  $e_j, j \in S_2$  are all parallel (and antiparallel to  $e_i$  for  $i \in S_1$ ). It follows that away from line-gons,  $M_r$  has a complex analytic structure. It turns out that the singularities are isolated (we shall see below that there are finitely many) and are contained in compatible complex analytic neighborhoods. This makes the moduli space  $M_r$  into a complex analytic space that is obtained as a result of symplectic reduction.

## 4 Geometric Invariant Theory

The algebraic side of this story comes in the form of Mumford's geometric invariant theory. The setting is an algebraic group (such as a matrix Lie group)  $G$  acting on an algebraic variety  $X$ . We would like to find a way of taking a quotient of  $X$  by the action of  $G$  and having the orbit space be an algebraic variety. The problem is that the ordinary quotient may not be an algebraic variety - it may not even be Hausdorff. For example, suppose  $X = \mathbb{C}^2$  and  $G = \mathbb{C}^*$  where the action is

$$\lambda \cdot (z_1, z_2) = (\lambda z_1, \lambda^{-1} z_2).$$

If  $z_1 \neq 0$  and  $z_2 \neq 0$ , the orbits have the form  $z_1 z_2 = c$  where  $c \in \mathbb{C}^*$ . For  $z_1 z_2 = 0$ , there are three orbits - the orbit of  $(0, z_2)$  where  $z_2 \neq 0$ , the orbit of  $(z_1, 0)$  where  $z_1 \neq 0$  and the orbit of  $(0, 0)$ . The latter consists of the single point  $\{(0, 0)\}$  whereas the other two orbits are the  $z_2$ - and  $z_1$ -axes minus the origin, respectively. Any open neighborhood of the orbit of  $(0, 0)$  in the orbit space must intersect other orbits, and the orbit space is therefore not Hausdorff.

Geometric invariant theory constructs another form of quotient, called the GIT quotient, that gets around such problems. As a matter of notation, the GIT quotient is denoted by  $X//G$ . In the example above, the GIT quotient is simply  $\mathbb{C}$ . The basic construction involves identifying the ring of  $G$ -invariants of  $X$ . The story is a bit simpler when  $X$  is an affine variety, but things get a little more complicated if  $X$  is projective. We will first discuss the affine case to illustrate the general strategy. Since our moduli spaces are projective, our goal is to understand the projective case. We will conclude this section with the Kirwan-Kempf-Ness theorem, relating GIT quotients to symplectic quotients. As usual, we will work over the field  $\mathbb{C}$ .

For the general theory of GIT quotients, the reader is referred to [MFK94].

<sup>4</sup>This is a consequence of the fact that  $\Omega$  is a Kähler form

## 4.1 The Affine Case

Suppose  $X$  is an affine variety defined by polynomials  $p_1, \dots, p_k$  in  $n$  complex variables. Let  $\mathcal{R}$  be the ring of functions on  $X$ :

$$\mathcal{R} = \mathbb{C}[z_1, \dots, z_n]/(p_1, \dots, p_k).$$

This gives us a natural embedding  $X \hookrightarrow \mathbb{C}^n$  as the space of all points  $z \in \mathbb{C}^n$  where  $p_i(z) = 0$  for all  $i = 1, \dots, k$ . In this setting,  $X$  is called the spectrum of  $\mathcal{R}$  and we write

$$X = \text{Spec}(\mathcal{R}).$$

This is equivalent to the set of all maximal ideals of  $\mathcal{R}$ .<sup>5</sup> If  $f : \mathcal{R} \rightarrow \mathcal{S}$  is a ring homomorphism and  $\mathfrak{p} \subset \mathcal{S}$  is a prime ideal,  $f^{-1}(\mathfrak{p})$  is a prime ideal of  $\mathcal{R}$ . This induces a map from  $\text{Spec}(\mathcal{S})$  to  $\text{Spec}(\mathcal{R})$ .

Now suppose  $G$  is a complex Lie group that acts on our ring  $\mathcal{R}$  by ring automorphisms. The action preserves prime ideals and hence acts on  $\text{Spec}(\mathcal{R})$  and thereby acts on  $X$ . A function  $f \in \mathcal{R}$  on  $X$  is  $G$ -invariant if  $g \cdot f(x) = f(x)$  for all  $g \in G$  and  $x \in X$ . Denote the set of all  $G$ -invariant functions on  $X$  by  $\mathcal{R}^G$ . It follows that  $\mathcal{R}^G$  forms a ring (with operations inherited from  $\mathcal{R}$ ) called the ring of invariants. We define  $\text{Spec}(\mathcal{R}^G)$  to be the GIT quotient of  $X$  by  $G$ :

$$X//G = \text{Spec}(\mathcal{R}^G).$$

Let us return to the example above where  $X = \mathbb{C}^2$  and  $G = \mathbb{C}^*$ . Since  $X$  is an affine variety defined solely by the zero polynomial, the ring of functions is  $\mathcal{R} = \mathbb{C}[z_1, z_2]$ . It is clear that the ring of invariants  $\mathcal{R}^G$  is generated by the polynomial  $z_1 z_2$ . If we let  $w = z_1 z_2$ :

$$\mathcal{R}^G = \mathbb{C}[w].$$

It follows that  $X//G = \mathbb{C}$ . What has happened geometrically is the orbits where  $z_1 z_2 \neq 0$  have been left unaltered, but we have identified the three orbits where  $z_1 z_2 = 0$ .

## 4.2 The Projective Case

To see why this construction isn't sufficient for the projective case, let  $X = \mathbb{C}^2$  and  $G = \mathbb{C}^*$  as above, but let the action be given by

$$\lambda \cdot (z_1, z_2) = (\lambda z_1, \lambda z_2).$$

The ring of functions  $\mathcal{R} = \mathbb{C}[z_1, z_2]$ , but the only invariant polynomials are constants and therefore  $\text{Spec}(\mathcal{R}^G) = X//G$  is just a single point. The obvious quotient *should* be  $\mathbb{CP}^1$ , but projective space is not  $\text{Spec}(\mathcal{S})$  for any ring  $\mathcal{S}$ . Therefore we need to do more work to obtain a GIT quotient for a projective variety. We will describe two equivalent constructions.

Suppose  $X$  is a projective variety. The first construction involves an embedding of  $X$  into  $\mathbb{CP}^n$  for some sufficiently large  $n$ . In the affine case, the corresponding embedding was handled using the ring of functions on  $X$ . We don't have that at our disposal in the projective case, since such functions would have to be constant. Consequently, we need more structure. Let  $\mathcal{L}$  be a line bundle over  $X$ . Let  $\Gamma(X, \mathcal{L})$  be the space of sections of  $\mathcal{L}$  and let  $(s_0, \dots, s_n)$  be a spanning set of its sections (not necessarily linearly

<sup>5</sup>This equivalence shows that the spectrum of  $\mathcal{R}$  is well defined, i.e. independent of the choice of polynomials  $p_1, \dots, p_k$ .

independent). We say that  $\mathcal{L}$  is *very ample* if for every  $x \in X$  there is  $i$  such that  $s_i(x) \neq 0$ .<sup>6</sup> This allows us to construct a closed embedding

$$X \hookrightarrow \mathbb{P}(\Gamma(X, \mathcal{L})^*).$$

Given  $x \in X$  we map

$$x \mapsto [f_x] = [s_0(x) : s_1(x) : \cdots : s_n(x)].$$

This is well defined since there is some  $i$  such that  $s_i(x) \neq 0$ . Identifying  $\mathbb{P}(\Gamma(X, \mathcal{L})^*)$  with  $\mathbb{C}\mathbb{P}^n$ , this gives us a closed embedding  $X \hookrightarrow \mathbb{C}\mathbb{P}^n$ .

Now suppose we have a Lie group  $G$  acting on  $X$ . Suppose the action lifts to an action of  $G$  on  $\mathcal{L}$  that is linear on fibers and takes the fiber  $L_x$  to the fiber  $L_{g \cdot x}$  for every  $g \in G$  and  $x \in X$ . Then we say that the action of  $G$  on  $\mathcal{L}$  linearizes the action of  $G$  on  $X$ , and that  $\mathcal{L}$  is a linearized line bundle. The linearization of the action preserves sections. As a consequence, we get an action of  $G$  on  $\mathbb{P}(\Gamma(X, \mathcal{L})^*)$  such that the embedding  $X \hookrightarrow \mathbb{P}(\Gamma(X, \mathcal{L})^*)$  is  $G$ -equivariant. We can thus consider  $G$  acting on  $X$  sitting inside of  $\mathbb{C}\mathbb{P}^n$ . If we let  $\pi : \mathbb{C}^{n+1} \setminus \{0\} \rightarrow \mathbb{C}\mathbb{P}^n$  be the natural projection, then  $\pi^{-1}(X)$  is an affine variety in  $\mathbb{C}^{n+1}$  that is invariant under dilations. The action of  $G$  lifts to an action on  $\pi^{-1}(X)$ , so we can consider the ring of **homogeneous** invariants. Taking the quotient again gives us a projective variety, and provides us with our construction of  $X//G$ .

In order to be able to prove anything about projective GIT quotients, we need to make this construction more concrete. A point  $x \in X$  is called *semi-stable* (with respect to  $\mathcal{L}$ ) if there is some  $m > 0$  and  $G$ -invariant section  $s \in \Gamma(X, \mathcal{L}^{\otimes m})^G$  such that  $s(x) \neq 0$  and the set  $X_s = \{y \in X : s(y) \neq 0\}$  is affine. If additionally the orbit of  $G$  through  $x$  is closed,  $x$  is said to be *stable* (with respect to  $\mathcal{L}$ ). Note that if  $x$  is stable with  $s(x) \neq 0$ , the orbit of  $G$  through any point  $y \in X_s$  is closed (see Chapter 8 of [Dol03]). A point  $x \in X$  that is not semi-stable is *unstable* (with respect to  $\mathcal{L}$ ). The set of semistable, stable, and unstable points are denoted by

$$X^{\text{ss}}(\mathcal{L}), X^{\text{s}}(\mathcal{L}), X^{\text{us}}(\mathcal{L})$$

respectively. It is clear that  $X^{\text{ss}}(\mathcal{L})$  and  $X^{\text{s}}(\mathcal{L})$  are open subsets of  $X$ , although they may be empty. When the line bundle is understood, we will omit the dependence on  $\mathcal{L}$ .

To construct the GIT quotient, we begin with  $X \setminus X^{\text{us}} = X^{\text{ss}}$ . We can cover  $X^{\text{ss}}$  with the affine open subsets  $X_{s_i}$ , take the affine GIT quotient of these open subsets and “glue them together” in an appropriate manner. This gives us the GIT quotient

$$X^{\text{ss}}//G$$

which is what we call  $X//G$ . This construction makes  $X//G$  into a projective variety. What actually happens is that the orbits of stable points in  $X$  become single points in  $X//G$ , while orbits of points in  $X^{\text{ss}} \setminus X^{\text{s}}$  are identified whenever the intersection of their closures is nonempty. For the details of this construction, the reader is referred to Chapter 8 of [Dol03].

### 4.3 Kirwan-Kempf-Ness Theorem

The Kirwan-Kempf-Ness Theorem connects GIT quotients to symplectic reduction on symplectic projective varieties. We suppose  $X$  is a projective variety with symplectic form  $\omega$  and a line bundle  $\mathcal{L}$  such that  $c_1(\mathcal{L}) = [\omega]$  in  $H_{\text{DR}}^2(X)$ , where  $c_1$  is the first Chern class. Suppose further that  $G$  is a Lie group acting on

<sup>6</sup>More generally, a line bundle  $\mathcal{L}$  is *ample* if there is some  $m > 0$  such that  $\mathcal{L}^{\otimes m}$  is very ample.

$X$  that linearizes  $\mathcal{L}$ . Let  $\mathfrak{g}$  be the Lie algebra over  $G$  and suppose the action of  $G$  admits a moment map  $\mu : X \rightarrow \mathfrak{g}^*$ . The first part of the Kirwan-Kempf-Ness theorem says that  $\mu^{-1}(0) \subset X^{\text{ss}}$ . Now let  $K \subset G$  be a maximal compact subgroup of  $G$ . The second part of the Kirwan-Kempf-Ness theorem says that the inclusion  $\mu^{-1}(0) \hookrightarrow X^{\text{ss}}$  induces a homeomorphism

$$\mu^{-1}(0)/K \cong X^{\text{ss}}//G.$$

If  $\mu^{-1}(0)/K$  is smooth, this is a diffeomorphism. If  $\mu^{-1}(0)/K$  is complex analytic, this is a complex analytic equivalence.

## 5 Polygon Spaces

### 5.1 The Weighted GIT Quotient of the Configuration Space $(\mathbb{S}^2)^n$

We can now apply this background to understand polygon spaces. We would like to find a complex-analytic equivalence between the moduli space  $M_r$  and the weighted configuration space  $((\mathbb{S}^2)^n, \Omega)$ . We will do this using the Kirwan-Kempf-Ness theorem. Denote  $((\mathbb{S}^2)^n, \Omega)$  by  $M$ . Since the underlying space is a product of copies of  $\mathbb{C}\mathbb{P}^1$ ,  $M$  is a projective variety. We will form a GIT quotient structure on  $M$ . The construction will depend on our choice of  $r$ . For this construction, we need to assume  $r \in \mathbb{Q}_+^n$  (see [Knu00]). However, since  $\mathbb{D}_2^n$  can be divided into chambers, each of which is relatively open in the subspace topology and hence contains a rational point, and since two points in the same chamber define equivalent moduli spaces, this is not too much of a restriction. See [Hu99] for the details.

The group  $G = \text{PSL}(2, \mathbb{C})$  acts on  $\mathbb{S}^2$ , and thus extends to a diagonal action on  $M$  by

$$A \cdot (u_1, \dots, u_n) = (A \cdot u_1, \dots, A \cdot u_n).$$

Given this action and  $r \in \mathbb{D}_2^n$ , the semi-stable points in  $M$  are the points  $\vec{u} \in (\mathbb{S}^2)^n$  such that

$$\sum_{u_j=v} r_j \leq 1$$

for every  $v \in \mathbb{S}^2$ . The stable points in  $M$  are those that satisfy the same condition with a strict inequality. As above, denote the semistable points by  $M^{\text{ss}}$  and the stable points by  $M^{\text{s}}$ . Let  $Q = M^{\text{ss}}//\text{PSL}(2, \mathbb{C})$ . Then  $Q$  is the GIT quotient  $M//G$  and is therefore a projective variety.

Define the cusp points to be  $M^{\text{cusp}} = M^{\text{ss}} \setminus M^{\text{s}}$ . Every point in  $M^{\text{cusp}}$  is determined by a partition of  $S = \{1, \dots, n\}$  into two disjoint sets  $S_1 = \{i_1, \dots, i_j\}$  and  $S_2 = \{j_1, \dots, j_{n-k}\}$  such that  $r_{i_1} + \dots + r_{i_k} = 1$  (and whence  $r_{j_1} + \dots + r_{j_{n-k}} = 1$ ). In the quotient, the cusp points are *uniquely* determined by the corresponding partition. Therefore, the subspace  $Q^{\text{cusp}} = M^{\text{cusp}}/G \subset Q$  is in one-to-one correspondence with a subset of partitions of  $n$ , which in turn is finite. Thus, in the quotient, there are at most finitely many cusp points.

Next, note that the closing condition

$$\sum_{i=1}^n r_i u_i = 0$$



implies that  $\tilde{\mathcal{M}}_r \subset M^{\text{ss}}$ . This is the first part of Kirwan-Kempf-Ness:  $\mu^{-1}(0) \subset M^{\text{ss}}$ . Since  $\text{SO}(3) \subset \text{PSL}(2, \mathbb{C})$  is a maximal compact subgroup, it follows from the second part of the Kirwan-Kempf-Ness that there is a complex analytic equivalence

$$\mathcal{M}_r \cong Q$$

which induces, via the Gauss map  $\epsilon$ , a complex analytic equivalence

$$M_r \cong Q.$$

Observe that under  $\epsilon$ , the cusp points  $Q^{\text{cusp}}$  correspond to the degenerate polygons in  $M_r$ . It follows that  $M_r$ , and hence  $\mathcal{M}_r$ , have at most finitely many singularities.

## 5.2 Moduli Spaces for Favorable Chambers

We will conclude this section by considering the moduli spaces for special vectors  $r \in \mathbb{D}_2^n$ . The hypersimplex is divided into chambers by walls of the form

$$W_J = \left\{ (x_1, \dots, x_n) \in \mathbb{D}_2^n : \sum_{i \in J} x_i = 1 \right\}$$

where  $J$  runs over all proper subsets of  $\{1, \dots, n\}$ . The chambers are polytopes (higher-dimensional generalizations of polyhedra). Note that two points  $x$  and  $y$  are in the same chamber if and only if for every proper subset  $J \subset \{1, \dots, n\}$

$$\sum_J x_j \leq 1 \iff \sum_J y_j \leq 1$$

and if the chamber is maximal (with respect to inclusion), the inequalities are strict.

For each  $i = 1, \dots, n$ , consider the wall  $W_{\{i\}}$ . Let  $\Delta_i$  be the unique maximal chamber in  $\mathbb{D}_2^n$  containing  $W_{\{i\}}$ . Theorem 6.14 in [Hu] states that if  $r$  is in the interior of  $\Delta_i$ , the moduli space  $M_r$  is isomorphic to  $\mathbb{C}\mathbb{P}^{n-3}$ . The quadrilateral example described in the introduction is an example of a moduli space that is isomorphic to  $\mathbb{C}\mathbb{P}^{n-3}$ . Since  $n = 4$  for a quadrilateral, this is the same as  $\mathbb{C}\mathbb{P}^1$ , which is diffeomorphic to  $\mathbb{S}^2$ . More generally, the discussion in the introduction shows that any  $r \in \mathbb{R}_+^n$  where there is some  $i$  such that  $r_i$  is sufficiently larger than the other  $r_j$ 's is contained in  $\Delta_{\{i\}}$ , hence  $M_r \cong \mathbb{C}\mathbb{P}^{n-3}$ .

## 6 Stable Polygons and Stable Curves

The moduli spaces  $M_r$  may have finitely many singularities, which can be resolved. There is a mechanism for resolving these singularities that applies to  $M_r$  for every  $r$ . This is the second result of [Hu99]. The mechanism grows out of the notion of stable polygons, which is connected to the moduli space of stable  $n$ -pointed curves of genus zero.

### 6.1 Stable Curves of Genus Zero

We start with the moduli space of  $n$  distinct points on  $(\mathbb{C}\mathbb{P}^1)^n$  modulo the action of  $\text{PSL}(2, \mathbb{C})$ , denoted by  $\mathcal{M}_{0,n}$ . This will contain all the generic points in the moduli space we will construct. The space  $\mathcal{M}_{0,n}$

is not compact, so we will add in enough points to form a compactification. We construct stable curves from  $\mathcal{M}_{0,n}$  as follows. We start by viewing a point in  $\mathcal{M}_{0,n}$  as  $n$  distinct points on a single copy of  $\mathbb{CP}^1$  and we let these points vary. As a pair of points get close to one another, we introduce a new copy of  $\mathbb{CP}^1$  intersecting the original  $\mathbb{CP}^1$  at the point of collision. The colliding points will then proceed along the new  $\mathbb{CP}^1$ . The end result will be a collection of intersecting copies of  $\mathbb{CP}^1$  with the extra restriction that each irreducible component (each copy of  $\mathbb{CP}^1$ ) has at least three points consisting of the original points that are left on that copy of  $\mathbb{CP}^1$  and intersections with other copies. This forces this process to stop after finitely many steps. The reason for the the number “three” is to prevent the existence of any nontrivial linear fraction transformation that can act on our space. This construction yields stable  $n$ -pointed curves of genus zero, and the moduli space of such stable curves is denoted  $\overline{\mathcal{M}}_{0,n}$ . The “genus zero” in the description comes from the fact that we constructed the curves out of  $\mathbb{CP}^1$ . The space  $\overline{\mathcal{M}}_{0,n}$  is a compactification of  $\mathcal{M}_{0,n}$  that illustrates a general procedure called the Deligne-Mumford compactification.

As an example, consider four points on  $\mathbb{CP}^1$ . A stable curve is illustrated in the cartoon below, where each line represents a copy of  $\mathbb{CP}^1$  and each circle either represents a point or an intersection.

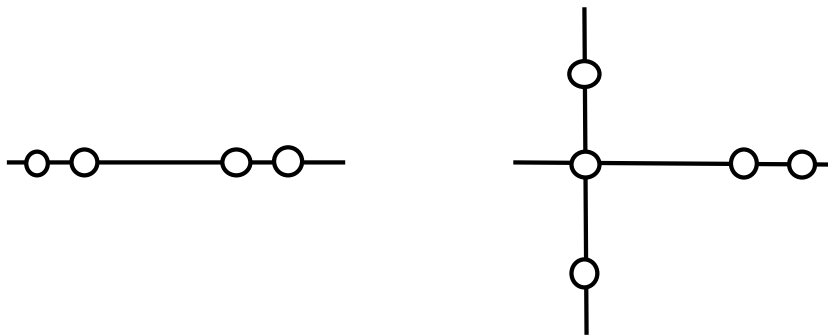

## 6.2 Stable Polygons

We do a similar construction to build stable polygons, but our building blocks will be a little bit more sensitive so a certain amount of care must be taken.

An  $n$ -gon is called **generic** if it does not have any parallel edges. We will denote the subspace of generic polygons by  $M_r^0$ . This space  $M_r^0$  can be identified with  $\mathcal{M}_{0,n}$  above, and as such is an open complex analytic space. We will compactify  $M_r^0$  by adding in appropriate limiting objects. The basic idea is that whenever a set of edges become parallel, we resolve by introducing a “bubble” polygon. This is done as follows. Suppose a polygon  $P$  is a limit of a sequence of polygons in  $M_r^0$  and  $P$  degenerates at a subset  $I$  of cardinality  $k$ . We then pair  $P$  with a generic  $(k + 1)$ -gon  $P'$  whose first  $k$ -sides inherit the lengths of the original parallel edges of  $P$  but whose last side length is  $r_{i_1} + r_{i_2} + \dots + r_{i_k} - \epsilon_{i_1, \dots, i_k}$  where the quantities  $\epsilon_{i_1, \dots, i_k}$  are chosen carefully. An illustration is below, where a 7-gon degenerates at three edges.

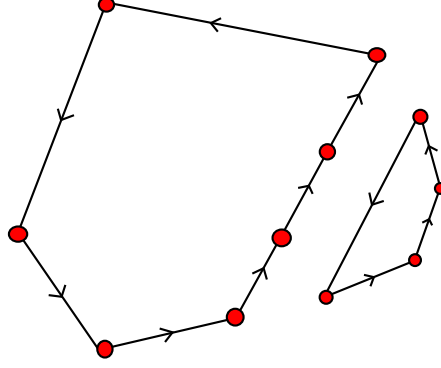

Different choices of these  $\epsilon$ 's will lead to equivalent complex analytic spaces but will end up with different Kähler structures. For us, it will suffice to use the same  $\epsilon$  in all cases. This can be done by letting  $\epsilon = \min\{r_1, \dots, r_n\}$ .

As a consequence of this choice, if we define

$$r_I = \left( r_{i_1}, \dots, r_{i_k}, \sum_I r_i - \epsilon \right)$$

then  $r_I$  lies in a favorable chamber  $\Delta_{k+1}$  in  $\mathbb{D}_2^{k+1}$ . It follows that  $M_{r_I}$  is isomorphic to  $\mathbb{C}\mathbb{P}^{k-2}$  and that no polygon in  $M_{r_I}$  degenerates at the  $(k+1)$ <sup>st</sup> edge. Note that  $P'$  can degenerate at other edges, in which case we pair  $(P, P')$  with a third polygon  $P''$  constructed similarly. Our choice of  $\epsilon$  guarantees that there are only finitely many degenerations that are possible, and hence this process terminates after a finite number of steps.

Given any proper subset  $I \subset \{1, \dots, n\}$  with  $|I| \geq 2$ , and given  $r_I$  as defined above, a pair

$$(P, P') \in M_r \times M_{r_I}$$

is called a *bubble pair* (and we call  $P'$  a *bubble of*  $P$ ) if  $P$  degenerates at the edges  $e_I$ . As discussed,  $P'$  never degenerates at its longest edge. Note that as a consequence of the triangle inequality,  $(P, P') \in M_r \times M_{r_I}$  being a bubble pair implies

$$\sum_I r_i \leq \sum_{I^c} r_i. \quad (6.1)$$

Accordingly, we say that a proper subset  $I \subset \{1, \dots, n\}$  with  $|I| \geq 2$  is a *relevant* subset if  $r$  satisfies (6.1). The collection of all relevant subsets of  $\{1, \dots, n\}$  will be denoted by  $\mathcal{R}(r)$ .

With this background, a *stable  $n$ -gon* with respect to the side length vector  $r$  is a collection of labeled (but not ordered) polygons

$$\mathbf{P} := (P_0, P_1, \dots, P_m) \in M_r \times M_{r_{I_1}} \times \dots \times M_{r_{I_m}}$$

where the  $I_j$ 's range over  $\mathcal{R}(r)$  and the following two properties are satisfied:

1. whenever  $I_t \subset I_s$ , then  $P_t$  is a bubble of  $P_s$ ,
2. if  $P_h$  does not have a bubble, then it is generic (i.e.  $P_h \in M_{r_{I_h}}^0$ ).

The moduli space of stable polygons is denoted  $\mathfrak{M}_{r,\epsilon}$ .

## 6.3 Results

Finally, we state the main results of [Hu99] that brings all of these ideas together.

**Theorem 6.1** *The moduli space  $\mathfrak{M}_{r,\epsilon}$  carries a natural smooth, compact complex analytic structure.*

**Theorem 6.2** *The moduli spaces  $\mathfrak{M}_{r,\epsilon}$  and  $\overline{\mathcal{M}}_{0,n}$  are biholomorphic. As a consequence, the complex structure of  $\mathfrak{M}_{r,\epsilon}$  is independent of  $r$  and  $\epsilon$ .*

Note that, as stated above, the Kähler structure may depend on the choices of  $r$  and  $\epsilon$ . It follows that one may use the moduli spaces of stable polygons to study the Kähler cone in  $H^2(\overline{\mathcal{M}}_{0,n})$ .

Our last result brings us back to our original moduli spaces of polygons  $M_r$ .

**Theorem 6.3** *By forgetting all the bubbles, we obtain a natural projection*

$$\pi_{r,\epsilon} : \mathfrak{M}_{r,\epsilon} \rightarrow M_r$$

*that is holomorphic and bimeromorphic. It is the iterated blow up of  $M_r$  along (the proper transforms of) some explicitly described subvarieties  $Y_\alpha$  when  $M_r$  is smooth. When  $M_r$  is singular,  $\pi_{r,\epsilon} : \mathfrak{M}_{r,\epsilon} \rightarrow M_r$  is the composite of a canonical resolution of singularities followed by explicit iterated blowups.*

This result allows us to view the moduli spaces  $M_r$  as a single family of smooth complex-analytic spaces  $\mathfrak{M}_{r,\epsilon}$  whether  $M_r$  started out as singular or not. For the explicit description of the subvarieties  $Y_\alpha$ , see Section 6 of [Hu99] and for a description of the blowup process, see Section 4 of Chapter II in [Sha88].

## 7 Conclusion

We start with something simple, a polygon in  $\mathbb{R}^3$  with prescribed edge lengths. Allowing the angles to vary, we obtain a topological space that can be realized as a symplectic reduction or as a GIT quotient, illustrating the Kirwan-Kempf-Ness theorem. Resolving singularities and blowing up along specified subvarieties yields a space biholomorphic to the Deligne-Mumford compactification of the space of  $n$ -pointed genus zero algebraic curves. In this sense, the moduli space of  $n$ -gons with a prescribed length is dominated by  $\overline{\mathcal{M}}_{0,n}$ .

## References

- [Dol03] Igor Dolgachev. *Lectures on Invariant Theory*. Cambridge University Press, 2003.
- [dS01] Ana Cannas da Silva. *Lectures on Symplectic Geometry*. Springer, 2001.
- [Ful00] William Fulton. Eigenvalues, invariant factors, highest weights, and Schubert calculus. *Bulletin of the American Mathematical Society*, 37(3):209–249, 2000.
- [Hal03] Brian C. Hall. *Lie Groups, Lie Algebras, and Representations: An Elementary Introduction*. Springer, 2003.
- [Har77] Robin Hartshorne. *Algebraic Geometry*. Springer, 1977.

- [HH04] Gert Heckman and Peter Hochs. Geometry of the moment map. Technical report, Spring School on Hamiltonian Systems, 2004.
- [Hu] Yi Hu. Relative geometric invariant theory and universal moduli spaces. *International Journal of Mathematics*, 7(2).
- [Hu99] Yi Hu. Moduli spaces of stable polygons and symplectic structures on  $\overline{M}_{0,n}$ . *Compositio Mathematica*, 118:159–187, 1999.
- [Hu07] Yi Hu. Geometric invariant theory and birational geometry. *Proceedings of International Congress of Chinese Mathematicians 2004*, pages 1–25, 2007.
- [Kap93] M. M. Kapranov. Chow quotients of Grassmanians. *Advances in Soviet Mathematics*, 16, 1993.
- [KM95] M. Kapovich and J. Millson. On the moduli space of polygons in the Euclidean plane. *Journal of Differential Geometry*, 42(1):133–164, 1995.
- [KM96] M. Kapovich and J. Millson. The symplectic geometry of polygons in Euclidean space. *Journal of Differential Geometry*, 44(3), 1996.
- [Knu00] A. Knutson. The symplectic and algebraic geometry of Horn’s problem. *Linear Algebra and Its Applications*, 319(1):61–81, November 2000.
- [MFK94] D. Mumford, J. Fogarty, and F Kirwan. *Geometric Invariant Theory*. Springer-Verlag, third edition, 1994.
- [Sha88] Igor R. Shafarevich. *Basic Algebraic Geometry*, volume 1. Springer-Verlag, second edition, 1988.